



Proposal for Generic Characterization of Electrical Test Benches for AC- and HVDC-Connected Wind Power Plants

Behnam Nouri¹, Ömer Göksu¹, Vahan Gevorgian², and Poul Ejnar Sørensen¹

¹Department of Wind Energy, Technical University of Denmark, Roskilde 4000, Denmark

²National Renewable Energy Laboratory, Golden, CO, USA

Correspondence: Behnam Nouri (beno@dtu.dk)

Abstract. The electrical test and assessment of wind turbines (WT) are going hand in hand with standards and network connection requirements. In this paper, the latest developments in the testing of the electrical characteristics of WTs, including IEC standards, compliance test methods, and industrial test benches, are studied. In this paper, the general structure of advanced electrical test benches, including grid emulator or controllable grid interface (CGI), wind torque emulator and device under test (DUT), has been proposed to harmonize the available industrial test sites. The AC and HVDC transmission systems impose different electrical characteristics on wind power plants (WPP). HVDC connection leads to a converter-based grid, yet AC connection has different grid characteristics in terms of grid impedance, short circuit ratio (SCR), inertia, and background harmonics. Therefore, this paper recommends performing compliance tests in two divisions as AC- and HVDC-connected WTs using a converter-based CGI and emulate the corresponding AC grid for DUT. Also, this paper recommends the additional tests for the current version of IEC 61400-21-1. The additional tests consist of test options for new features of modern WTs, such as Grid-forming, system restoration, and black start capabilities, as well as emulation of different grid characteristics, such as detailed power system, inertia, SCR, and different grid connection emulations for DUT. This way, the possibility of research, development, and demonstration studies on WTs and WPPs would increase. The proposed additional tests can be implemented using the available advanced test benches by adjusting their control systems. Since most of the industrial test benches are based on converters, the characteristics of a real power system can be emulated by a CGI coupled with real-time digital simulator (RTDS) systems through high-bandwidth power-hardware-in-the-loop (PHIL) interface.

1 Introduction

Wind energy has been one of the most promising renewable energy sources (RES) used worldwide, mostly located onshore. Besides, a better quality of the wind resource and larger suitable areas in the sea have made offshore installations a considerable choice for Wind Power Plants (WPPs). To date, the total installed capacity has reached 592 GW with 23 GW share of offshore in 2018. The new total installations would continue with more than 55 GW each year by 2023 (GWEC (2018); Wind Europe (2018)).

The increasing installed capacity of variable renewable generation (VRG) has concerned power system operators in terms of stability and reliability of the overall system. Consequently, new interconnection requirements, standards, and market mech-

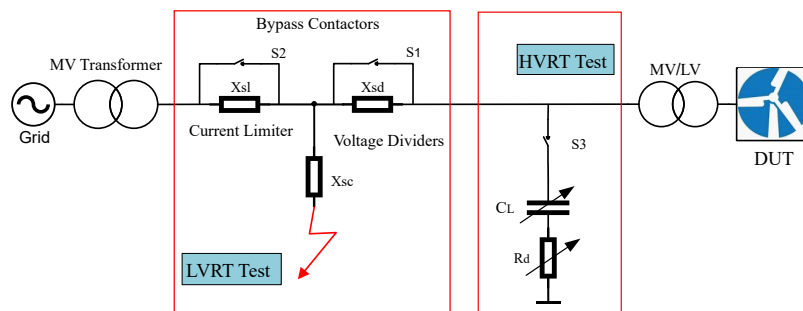

Figure 1. The basic structure of impedance-based topology for LVRT and HVRT capabilities tests.

25 anisms are evolving in various parts of the world for VRGs, including wind power, to provide various types of essential reliability services to the grid – the role that has been typically reserved for conventional generation. Furthermore, the industry has focused on collaborations and harmonization to achieve the technical and economic benefits of a uniform technology and market, especially in Europe (IRENA (2018); PROMOTioN D11.1 (2019); NERC (2015)). In this way, the European Commission has regulated international requirements for AC- and HVDC-connected power-generating modules as well as HVDC systems (Commission Regulation 631 (2016); Commission Regulation 1447 (2016)). Consequently, compliance test standards are needed to ensure the power quality and performance of renewable energy systems, especially WPPs.

35 Compliance test methods are in line with relevant network codes and standards. Furthermore, wind technology has been matured by research, development, and demonstrations in industrial test sites and laboratories. Power quality and transient performance during faults have been essential aspects, which needed to be tested and verified. Figure 1 illustrates the basic compliance test topology, which had been proposed for low voltage ride-through (LVRT) capability test in Ausin et al. (2008) and is given as an example in IEC 61400-21-1 (2019). Recently, this structure has been adapted for high voltage ride-through (HVRT) capability test as well (Langstadtler et al., 2015). In this topology, the voltage divider impedances (X_{sd} and X_{sc}) are used for the LVRT test of the device under test (DUT). Also, the parallel capacitors (C_L) in series with damping resistors (R_d) are used for the HVRT test. X_{sl} is used to limit the effect of tests on the utility grid. The test apparatus structure shown in
40 Figure 1 had proven to be a useful tool in the early stages of grid integration research and criticism of utility-scale wind power. However, it has certain fundamental limitations, such as dependence on a stronger point of interconnections and an inability to replicate any evolving grid characteristics.

This structure has been used in some industrial test sites; however, by increasing wind power installations, the requirements and appropriate test methods are needed to study the reliability, stability, harmonic interactions, and control performance of
45 WPPs in connection to different types of AC and HVDC transmission systems according to (Langstadtler et al., 2015), (Asmine et al., 2017), (Gevorgian et al., 2016) and (Zeni et al., 2016). Thus, it is essential to adapt or define new regulations, standards, and compliance test methods to analyse the increasing challenges concerning wind energy.

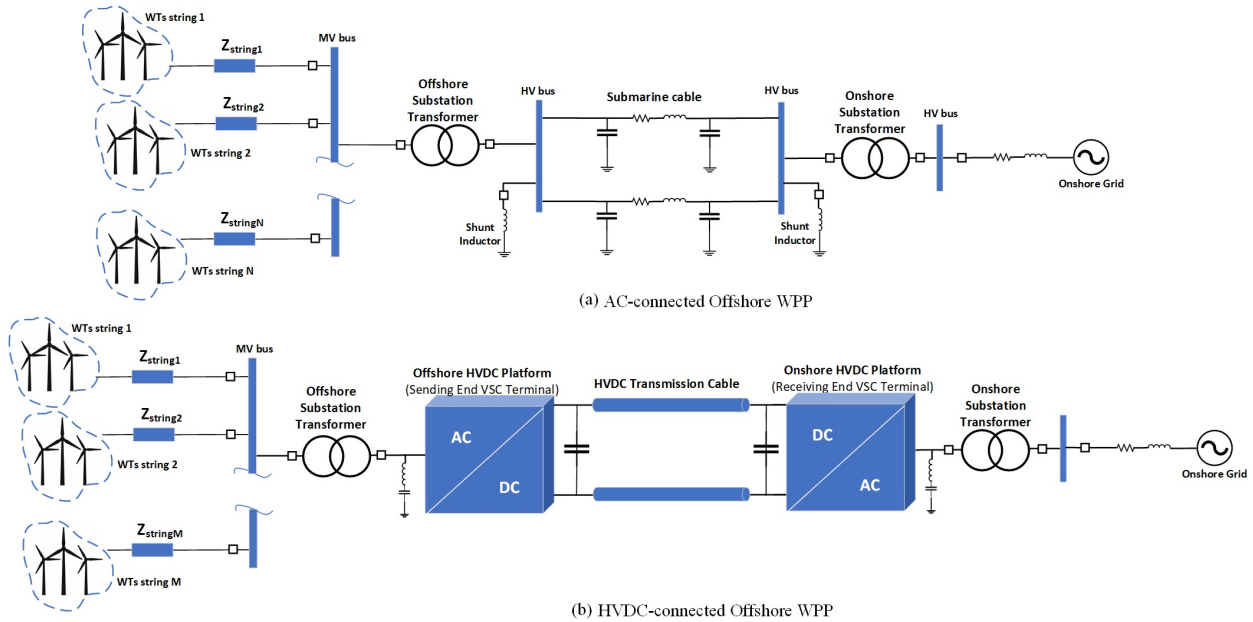

Figure 2. Typical structure of AC (a) and HVDC (b) connected WPPs.

In this paper, the authors wish to extend the international harmonization efforts in wind energy towards harmonized test methods and propose additional test options to the standard tests to extend the applications of advanced industrial test benches in terms of research and development studies. In part 2, the typical structures of WPPs, as well as IEC standards and electrical test levels for assessment of wind energy, have been introduced. Part 3 summarizes the industrial test benches and illustrates a generic structure of available advanced test apparatuses. In part 4, the characteristics of a test bench have been discussed, and the electrical characteristics of power systems in connection with WPPs have been studied. Finally, part 5 proposes the generic structure of test options consisting of the recommended tests in IEC standard as well as proposed additional test options for compliance tests, and research and development studies.

2 Electrical Tests for Wind Turbines

The integration of wind energy into the power system has been one of the main challenges for the development of WPPs. The wind power can be transmitted either through AC or HVDC transmission systems to the main AC grids. Figure 2 illustrates a typical structure for AC and HVDC connections of WPPs. HVDC connection has economic advantages for long distances, especially in case of offshore WPPs (Hertem et al. (2016); Cutululis (2018); Das et al. (2017)). According to the European wind energy association (EWEA) (Pierria et al., 2017), potentially, the European offshore wind power can supply Europe seven times more than necessary. Hence, the recent interests in Europe are focused on offshore WPPs, and HVDC systems are required due to distances from the main AC grids. The collector system voltages in AC- and HVDC-connected WPPs are



typically 33 kV and 34.5 kV in Europe and the U.S., respectively. Recently, several 66 kV collector systems in offshore WPPs
65 have been demonstrated. Therefore, 66 kV seems to be a general trend in collector system design in the offshore wind industry
(Wiser et al., 2018).

The network connection requirements have been developed by transmission system operators (TSO) in different countries
to eliminate the wind power integration challenges and related power system stability risks. At the same time, the industry
has driven the development of test methods to assess and validate the demanded capabilities from WTs and WPPs. Thus, the
70 development process of network codes and compliance test methods happened by the maturation of wind energy as new tech-
nology. Also, the industry is currently interested in the technical and economic benefits of international collaborations (Wind
Europe (2018); IRENA (2018)). Therefore, harmonized regulations and standards are in progress for design and performance
assessment of WTs as well as WPPs. The development of European network codes and IEC standards are some of the best
harmonization practices in Europe.

75 In European network codes, the requirements have been regulated for AC-connected offshore and onshore as well as HVDC-
connected power-generating modules (PGM) (Commission Regulation 631 (2016); Commission Regulation 1447 (2016)). Ac-
cording to (Nouri et al., 2019), the requirements for AC-connected offshore and onshore PGMs are mostly similar, while
relatively different operation ranges and conditions have been considered for AC- and HVDC-connected PGMs. The AC and
HVDC transmission systems impose different electrical characteristics on WPPs. Consequently, different control schemes and
80 design considerations have been used for WTs as well as WPPs. Therefore in this paper, the authors are proposed to perform
compliance tests in two divisions as AC- and HVDC-connected WTs using a converter-based CGI and emulate similar grid
characteristics for DUT. Although, reflecting all aspects of an AC or HVDC connection is challenging, but at the same time, es-
sential to assess the reliability of WTs. Compliance test methods and standards are critical factors in maintaining the reliability
and stability of WPPs. In the next section, IEC standards for test and assessment of wind turbines have been reviewed.

85 **2.1 IEC Standards for Assessment of Wind Energy**

In 1988, Technical Committee 88 (TC88) of the IEC began its efforts to organize international standards for wind turbines
as 61400 series. TC88 consists of many working groups, projects, and maintenance teams to develop and issue standards,
technical reports, and specifications. Initially, TC88 focused on power performance (i.e., power curve) tests and structural and
mechanical design. The works on electrical tests started in 1997 as IEC 61400-21 series by the working group WG21.

90 The evaluation of performance and quality of WPPs is based on measurements, simulations, and tests. The second edition
of IEC 61400-21 was published in 2008 to cover the definition and specifications for measurement and assessment of power
quality characteristics for wind turbines. Currently, IEC TC88 WG21 is working on four new documents for the IEC 61400-21
series, where the title is changed from power quality characteristics to electrical characteristics appreciating that not only power
quality characteristics are included. To date, there is no IEC standard for testing the electrical characteristics of WPPs, but only
95 for testing single WTs.

Recently, IEC 61400-21-1 is published and replaced the second edition of 61400-21. IEC 61400-21-1 specifies test meth-
ods for electrical characteristics of wind turbines (IEC 61400-21-1, 2019). Also, IEC 61400-21-2 specifies test methods for



electrical characteristics of WPPs (Andresen et al., 2019). Concerning the growing issues regarding harmonics in WPPs, IEC 61400-21-3 aims to focus on harmonic modeling as a technical report. The IEC TR 61400-21-3 provides a starting point for the required frequency-domain modeling of wind turbines (IEC TR 61400-21-3, 2019). Furthermore, the IEC 61400-21-4 recommends a technical specification for component and subsystem tests (Andresen et al., 2019). IEC 61400-21-1 and 21-3 are published in 2019, while 61400-21-2 and -21-4 may be published in 2021.

The IEC 61400-27 series specifies standard dynamic electrical simulation models for wind power generation. The first edition of IEC 61400-27-1, published in 2015, specifies generic models and validation procedures for wind turbine models. Furthermore, the next edition is under development to expand the scope towards WPPs models in addition to the WTs models (Das et al., 2016). The next edition consists of two parts: IEC 61400-27-1 specifying generic models for both WTs and WPPs, and 61400-27-2 specifying validation procedures.

2.2 Electrical test levels

According to the IEC-61400-21-1 (IEC 61400-21-1, 2019), the electrical characteristics to be simulated and validated for wind turbines consist of five different categories as power quality aspects, steady-state operation, control performance, transient performance (fault ride-through capability), and disconnection from the grid. The electrical characteristics of WTs can be measured and tested at different levels. Test levels consist of component test level (such as capacitors and switches), subsystem test level (such as nacelle and converter), field measurement at wind turbine level (or type test), and field test or measurement at WPP level (IEC 61400-21-1, 2019). WT level tests can also be split into two subcategories: (a) testing of the full drive-train connected to low voltage test bench; (b) testing of the full drive-train connected to medium voltage test bench via WT's transformer with a full set of protection and switchgear. The second option is closer to reality since it includes impacts of transformer impedance and configuration and protection settings on transient performance. In IEC 61400-21-1 (2019), an overview of the required and optional test levels for different test and measurement requirements are given.

Nowadays, to have a flexible and economical solution for compliance tests and validations, the trend is to perform tests at lower levels, such as WT and subsystem test levels. The tests for WT and subsystem levels are mostly implemented in a research and development environment or test sites. However, in some cases performing a field test is still necessary as reported based on some experiences. Accordingly, the Hydro-Québec TransÉnergie experience (Asmine et al., 2017) regarding the inertial response has shown that an adequate evaluation of the inertial response cannot be done accurately at WT level and should include an evaluation performed at the WPP level. Also, the power quality assessment of WPPs is either assessed using scaling rules of WT test results or accomplished by the assessment of online measurement data. The online monitoring is achieved during the first year of operation of the WPP. The owners of power plants should ensure that their connection to the local grid does not cause voltage distortion or fluctuation more than an acceptable level. However, the increasing challenges, such as harmonic resonances and voltage and frequency stability issues, have proven the need for more extended analysis and assessment of WPPs.

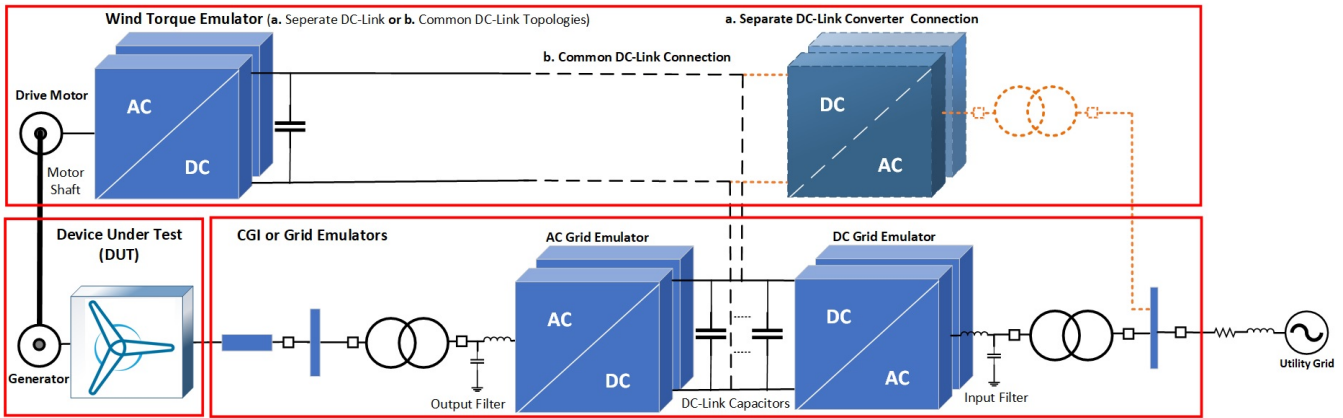

Figure 3. The generic schematic diagram of a converter-based test bench.

130 3 Industrial Test Benches for Wind Energy

Different electrical test benches as a controllable grid interface (CGI) have been reported for grid dynamics emulation in Ausin et al. (2008), Espinoza et al. (2019), Espinoza et al. (2015), and Yang et al. (2012). The impedance-based test equipment in Figure 1 is only intended for the fault ride-through capability tests. A more advanced and flexible topology is a full-power converter-based CGI, which is shown in Figure 3. This topology is used in the latest industrial test benches and is studied in

135 the next parts of this paper.

In MEGAVIND (2016), a mapping of global test and demonstration facilities serving the western wind industry is given by topics and locations. Accordingly, most of the latest industrial test benches are based on power electronic converters. The attractiveness of the converter-based test benches is enhanced control and test opportunities for both electrical and mechanical aspects of WTs. Converter-based test equipment allows emulation of unlimited test scenarios applicable to power systems of various sizes (sizeable interconnected power grids, island systems, or mini-grids) operating at both 50 Hz or 60 Hz, with full controllability over strength, imbalances and harmonic content of emulated grids. The generic schematic diagram of a converter-based test rig is shown in Figure 3. Generally, an industrial test bench for wind energy consists of three main parts: device under test (DUT), wind torque emulator, and grid emulator (or CGI). In Figure 3, the DUT is a WT nacelle. The CGI can also be used for testing of complete WTs in which case the wind torque emulator in Figure 3 is not needed.

145 In Table 1, the specifications for some of the advanced industrial test sites are illustrated. As it is shown, the three-level neutral point clamped (3L-NPC) drive converter modules in parallel connection is a typical topology that is used to establish a medium power and medium voltage source as grid and wind emulators (Averous et al. (2017); Gevorgian (2018); Jersch (2018) and Rasmussen (2015)). NPC topology is a very efficient multilevel converter type that is developed to achieve lower harmonic distortion rather than conventional two-level converters and reduce the size of demanded filtering and undesired interference.

150 According to the Table 1, a group of test benches such as available test setups in NREL (National Renewable Energy Laboratory, USA), IWES (Fraunhofer IWES Institution, Germany) and CENER (National Renewable Energy Centre, Spain),



Table 1. Comparison of different concepts applied in industrial test benches.

Test Centre	CGI rating (MVA)	Short circuit capacity	Wind Emulator rating	Converters type	*N (DEM)	**M (AEM)	Converter controller	RTDS
LORC	15 MVA	30 MVA	13 MVA	3-level NPC GE (IGBT)	2	2	AVC	no
Aachen	3.5 MVA	7.5 MVA	4 MVA	3-level NPC GE (IGBT)	1	1	AVC	yes
NREL	7 MVA	40 MVA	5 MVA	3-level NPC ABB (IGCT)	1	4	DTC	yes
IWES	10 MVA	44 MVA	9 MVA	3-level NPC ABB (IGCT)	2	3	DTC	yes
CENER	9 MVA	18 MVA	9 MVA	3-level NPC ABB (IGCT)	1	2	DTC	yes

*N(DEM): Number of DC grid emulator modules, **M(AEM): Number of AC grid emulator modules.

are using three-level NPC drive converters developed by ABB company. The ABB drive converters are controlled by direct torque control (DTC) method with IGCT switches (ABB, 2018). On the other hand, in the second group, such as LORC (Lindø Offshore Renewables Center, Denmark) and Aachen (RWTH Aachen University, Germany), the converters are three-level NPC converters developed by GE (General Electric). GE’s medium power drive converters are controlled by advanced vector control (AVC) using IGBT switches (GE, 2018). Each converter developer uses different components, control methods, and interface algorithms. However, all of the test benches should be able to perform tests according to the standards and research objectives and minimize the effect of non-ideal emulation of a real environment for DUT. In most of the test sites, a real-time digital simulation (RTDS) system is used to get to a dynamic online model of the grid as well as the overall system. The main limitation of converter topology shown in Figure 3, as well as any converter-based test rigs, is limited over-current capability. This constraint can be addressed by over-sizing the MVA rating of the test side converter similar to what was done in NREL’s CGI (7 MVA continuous power rating but capable of operating at 40 MVA short circuit capacity during 2 seconds) as given in Table 1. Over-sizing of converters for this purpose may seem costly but is necessary for LVRT testing of doubly-fed induction generator (DFIG) type WTs that can produce higher levels of short circuit current contribution.

The establishment of test facilities would be based on different criteria, objectives, and motivations. The majority of companies have plans to develop their sites as such to be able to test a wide range of WTs, including medium power to higher power ratings, which are mostly for offshore applications. According to ABB (Pietiläinen, 2018), the new trends in the development of grid simulators are as follow:

- Higher power ratings: up to 24MW rating and 80MVA short circuit power.
- Grid impedance emulation: virtual impedance emulation using the converters control system.
- Higher bandwidth for harmonic injections: up to 25th or 50th or even 100th harmonics injection for stability tests.



- Extension of use for component and sub-system tests. Also, mobility of equipment to test installed DUTs in the field.

The three main parts of the generic converter-based test rig, which is shown in Figure 3, are introduced as follows.

3.1 Device Under Test (DUT)

175 The main objective of test facilities is to perform compliance electrical and mechanical tests in the WT test as well as sub-system test levels on DUT. Test results are used to evaluate the behavior of DUT during dynamic and steady-state operations according to test standards. DUT can be one or more numbers of a whole WT or its sub-systems such as a nacelle consisting of converters and generator, or only converters of a WT. Nowadays, WTs are mainly full-converter or DFIG types in new developed WPPs.

180 3.2 Grid Emulator (CGI)

The grid emulator or CGI consists of two back-to-back converter units for a real grid emulation for DUT, as it is illustrated in Figure 3. One converter unit is connected to the utility grid through a transformer as an active rectifier. This unit would be called as "DC grid emulator." Generally, the control objective for the DC grid emulator is to regulate the DC-link voltage in a reference value within an acceptable variation range. The reference value for DC-link depends on the type and objectives of
185 the test. Thus, the DC grid emulator should perform as a current source to exchange active and reactive power between the DC-link capacitors and the utility grid.

The second converter unit is connected to the DUT through a transformer. The controller in the DUT side is designed to emulate a real grid dynamic and steady-state behavior. The second converter unit would be called as "AC grid emulator." Besides, to have an acceptable range of total harmonic distortion (THD) and to prevent unwanted harmonics and noise interferences in
190 the setup, appropriate passive filters on both sides of the converters have been considered. Also, in some cases, active filtering methods are implemented by additional control strategies such as selective harmonic elimination (SHE) and inter-leaved harmonic elimination methods, to decrease the need for the large passive filters (Gevorgian et al. (2016) and Averous et al. (2017)). Thus, by this structure, the power flow in the CGI is controlled. Meanwhile, the assessment of DUT behavior is done by online simulations, measurements, and data analysis.

195 3.3 Wind Torque Emulator

Assessment of electro-mechanical interactions of WTs can be achieved by using the wind torque emulator part in the test bench. As it is shown in Figure 3, the wind torque emulator would be connected directly to the DC-link of CGI as a common DC-link, or have a separate converter unit connected to the utility grid. Separate DC-link for the wind torque emulator enables an independent control system and reduces the side-effects of power electronic converters on each other such as harmonics
200 interference, DC-link voltage ripple, and control interactions.

The wind torque emulator is a prime mover system consisting of a drive converter connected to an AC or DC motor. The motor drive system is used to simulate wind profile to the shaft of WT's generators. So, the drive system can emulate mechanical



load, mechanical torque, and wind speed for DUT. The drive system converts the electrical power to the mechanical power for the shaft of the generators. On the other hand, the generators convert the mechanical power to the electrical power in connection to the CGI. In this way, the power flow circulates through the utility grid, wind torque emulator, and grid emulator.

The first constraint is power loss during these power conversions and circulations. Also, the second constraint for the power flow is during the LVRT capability test. During voltage sag emulation by the AC grid emulator for the DUT, the DC grid emulator has to provide the active power to the wind power emulator. Thus, the maximum required power flow and power losses during tests should be considered in the cooling system design.

210 **4 Test Bench Characteristics**

The advanced specification of test facilities not only make it possible to perform network code compliance tests, but also give the opportunity to analyze, understand, and predict possible challenges facing wind energy technology, and even further to develop solutions and perform prototype tests. In this section, the authors have studied the characteristics of an advanced test bench.

215 **4.1 Emulated Grid Characteristics**

The characteristics of a real power system that test article is exposed to at its point of common coupling (PCC) can be emulated by CGI coupled with RTDS through high-bandwidth power-hardware-in-the-loop (PHIL) interface. This way, the grid emulator can replicate all characteristics of PCC for testing DUT. The emulation should consider the electrical characteristics of power grids, such as grid impedance, effective short circuit ratio, inertia, and background noise.

220 **4.1.1 Grid Impedance**

One of the main differences between AC and HVDC connections is the structure of equivalent grid impedance. Especially in AC-connected offshore WPPs with long AC export submarine cables, the grid impedance is high and frequency-dependent, which can cause resonances and instability. Also, in the case of onshore AC connections, the main issue would be considerably high grid impedance for remote WPPs. Typically, for AC offshore connections, the grid impedance would be considered capacitive, while for AC onshore connections, it would be high inductive impedance. While, regarding HVDC-connected offshore WPPs, the equivalent resistance of the grid impedance is low. Thus, the natural resonance damping capability in such grids is low, and the converters of WTs are prone to interact with the converters of the HVDC system. Therefore, the harmonic stability of an HVDC connection is very vulnerable. The interactions among grid impedance, converters controller, and passive filters can cause stability and resonance problems in a WPP as well as HVDC station (Buchhagen et al. (2015); Kocewiak et al. (2013) and Sowa et al. (2019)).

In contrast, in a synchronous generator-based grid, large electrical loads help the grid stability during dynamics and resonances. Therefore, it is essential to consider the emulation of grid impedance characteristics in the test environment and test results.



4.1.2 Short Circuit Ratio

235 As the AC system impedance increases, the voltage magnitude of the AC system becomes even more sensitive to the power variations at the PCC. This difficulty is usually measured by the short-circuit ratio (SCR), which is a ratio of the short-circuit capacity (S_{sc}) versus the rated power of the AC grid at PCC (P_{npcc}) as illustrated in equations (1) and (2) (IEEE Std. 1204, 1997).

$$S_{sc} = \frac{V_{pcc}^2}{Z_{grid}} \quad (1)$$

240 Where Z_{grid} is the equivalent impedance of the grid and V_{pcc} is the nominal phase-to-phase voltage at PCC.

$$SCR = \frac{S_{sc}}{P_{npcc}} \quad (2)$$

The investigations in Fan and Miao (2018) have shown that a weak grid interconnection of an AC-connected WPP (e. g., ERCOT, USA) can lead to poorly damped or undamped voltage oscillations. The SCR evaluation for an HVDC-connected AC grid is defined as an effective short circuit ratio (ESCR). ESCR is the ratio of the short-circuit power of the AC grid along with HVDC converter filters and capacitor banks to the rated power of the HVDC link, as shown in equation (3). Typical weak HVDC-connections have ESCR less than 2.5 (Yogarathinam et al., 2017).

$$ESCR = \frac{S_{(AC+HVDC)}}{P_{HVDC}} \quad (3)$$

The HVDC transmission limitations imposed by AC system strength, AC grid impedance characteristics and converter phase-locked loop (PLL) parameters have been investigated in Zhou et al. (2014). These studies have shown that the operation of the HVDC converter is greatly affected by the angle of the AC grid impedance. As the impedance becomes more resistive, the minimum required SCR at the rectification side converter of the HVDC system increases, in contrast, it decreases at the inverting side converter. Also, results have shown that the gains of the PLL, significantly affect the operation of the HVDC converter, particularly at low ESCRs (less than 1.3). For stronger AC networks, the VSC system works well as long as the PLL gain is kept sufficiently large to provide an adequate damping coefficient (Zhou et al., 2014).

255 The converter-based test bench has a similar structure to an HVDC connection system with two back-to-back converters. Thus it can be used to emulate an HVDC system with high or low ESCRs for DUT. This emulation would be implemented by adjusting the control system or modular selection of the CGI converters, especially in a test setup consisting of an RTDS system.

4.1.3 Grid Inertia

260 The grid inertia is another important criterion for evaluation of grid strength. In this way, the effective inertia constant (H_{dc}) for an HVDC-connected AC grid is defined as the ratio of the total AC system inertia (TSI) in MW-s to the MW rating of the HVDC link which is illustrated in equation (4).

$$H_{dc} = \frac{S_{TSI}}{P_{HVDC}} \quad (4)$$



H_{dc} is less than 2.0 for weak grids (Yogarathinam et al., 2017). In an HVDC-connected offshore WPP, there is no rotating
265 mass. Therefore the inertia is zero. The test bench converters can be considered as an HVDC system connection for DUT. In
this way, using the CGI control system, it is possible to emulate different inertia ranges to evaluate the control performance of
WTs.

4.1.4 Background Harmonics

The background noise and harmonics are high-frequency content in the grid voltage as part of harmonic sources. By increasing
270 converter-based installations, the harmonic injection and interactions have concerned the power system operators and WPP
developers. The possible harmonic challenges can be studied in two main categories as follows:

- Harmonic emission sources: Non-ideal power sources and non-linear loads generate harmonics. Thus, the harmonic
emission is a power quality issue, and the assessment is done by measurements (Sørensen et al., 2007). From power
quality point of view, the harmonic emission is important because of power loss, system operation interference, and
275 overall cost. The assessment of emission limits for the connection of distorting installations at medium and higher
voltage levels is recommended in IEC 61000-3-6 technical report. The emission limits depend upon the agreed power of
the connected power plant and the system characteristics (Joseph et al., 2012).
- Harmonic stability issues: Primarily, harmonic stability problems are significant in the case of fully renewable-based
power grids; since converters mostly dominate them. Therefore, HVDC-connected offshore WPPs are the main subject
280 of harmonics and resonance studies. As an example, BorWin1, which is the first offshore HVDC station and is developed
to transmit wind energy from BARD offshore WPP to the onshore grid in Germany. So far several serious problems such
as outages of the HVDC station, severe harmonic distortion, and resonances in the offshore grids, have been reported
because of harmonic interactions among active components such as power converters, and passive components such as
filters and grid impedance (Buchhagen et al. (2015); Kocewiak et al. (2013); Kocewiak et al. (2017)). Also, it is crucial
285 to note that the current limits recommendations in the standards do not apply to harmonic currents that are absorbed by
the WPPs from the background harmonic source of the grid. Therefore, series and parallel resonances from the collector
cable capacitance can easily occur in the WPP, absorbing more harmonic current than designated by the standards (Bradt
et al. (2011) and Preciado et al. (2015)). One of the promising study proposals for the harmonic stability of converter-
based power systems is impedance-based analysis (Sun, 2011). The experimental verification of the impedance-based
290 stability analysis method is presented in PROMOTiON D16.5 (2019).

According to Bradt et al. (2011), in the case of harmonic studies, the utility grid is characterized by two groups of parameters:
The first category is the background voltage distortion present at the PCC without connection of the WPP. The second category
is the driving-point impedance of the grid at harmonic frequencies, which consists of transmission system harmonic impedance
and reactive compensation equipment equivalent impedance. The harmonic content of the synchronous generator-based grids
295 would contain low order harmonics due to non-linear loads. While a converter-based grid mainly would have high order
harmonics generated by high-frequency switching concepts of the power converters. Therefore, it is essential to emulate the



real grid background harmonics in test facilities and evaluate the performance of DUT with the presence of grid harmonics. However, high order harmonic injection would need high bandwidth in the output transformer of the AC grid emulator and the measurement instrument.

300 4.2 Utility Grid Effects on a Test Bench

The interconnection of the grid emulating CGI and the utility grid depends on their characteristics. If the utility grid had low SCR, then the CGI connection to the utility grid would be very similar to an HVDC connection to a weak AC grid. According to Durrant et al. (2003), using current vector control for converters, only 0.4 pu power transmission can be obtained for DC-link, where only in one of AC sides of the CGI (DUT or utility grid sides), the SCR is 1 pu. However, by using more efficient control
305 methods or increasing DC-link capacitance, it can be increased to higher than 0.8 pu (Zhang and Harnefors, 2011). Also, the connection of CGI to the utility grid should comply with the local network connection codes concerning power quality aspects. Therefore, it is vital to consider the local grid characteristics and connection requirements in design and control strategies for the test bench.

5 Test Options for Advanced Test Benches

310 In general, control of a WPP is managed by two control systems: WPP control level, and WT control level. Thus, the AC grid emulation would be performed by real-time calculations, simulations, and look-up tables. The CGI controllers can be designed based on the different types of compliance tests, and research and development studies. The test of DUT should be done as such to ensure the emulators would not affect the test results. In Figure 4, the proposed control structure for advanced test
315 benches is illustrated. Depending on the test modes and study objectives, the reference values for the controllers of the test bench converters would be calculated using either power-hardware-in-the-loop (PHIL) interface or real-time system model calculations (Averous et al. (2017) and Koralewicz et al. (2017)).

The blade and wind torque control unit for wind torque emulator would be necessary in the case of WT's nacelle tests. Typically, the nacelle of WT contains gearbox, generator, converters, and output transformer. Since the mechanical parameters vary slower than electrical parameters, the speed or torque references can be chosen as set-points in short-term studies for
320 electrical tests. However, for long-term studies, the aerodynamics, pitch control, and mechanical loads could be considered in control of the wind torque emulator. According to Figure 4, the torque or speed references for the drive system can be derived from real-time calculations based on blade aerodynamics and mechanical models, and wind speed time series. The control methods for converter-based CGI have been discussed in Gevorgian et al. (2016),Zeni et al. (2016),Espinoza et al. (2019), Espinoza et al. (2015) and Koralewicz et al. (2017).

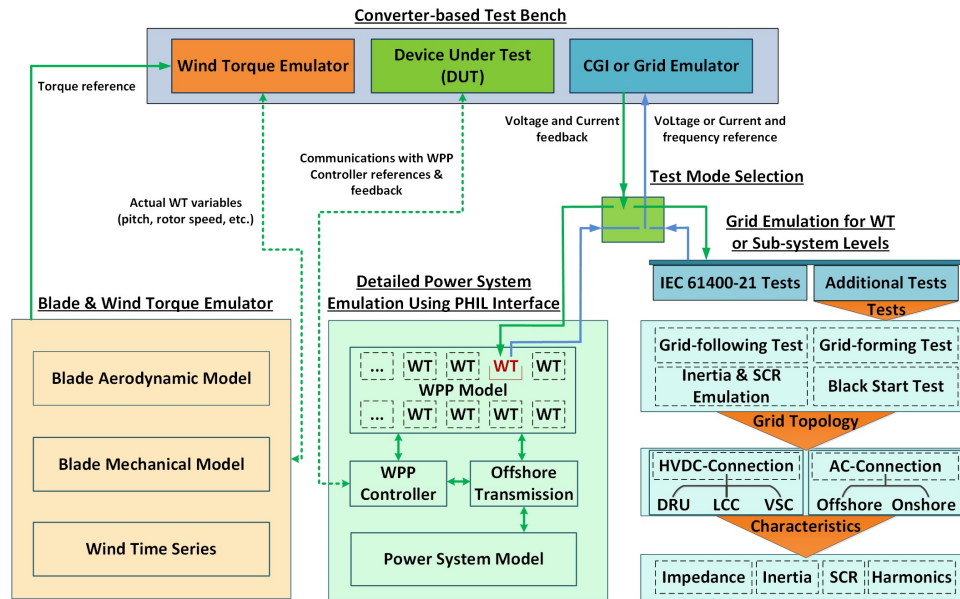

Figure 4. Proposed control structure for converter-based test benches.

325 5.1 IEC 61400-21 Standard Tests

Nowadays, most of the industrial test benches have been focused on performing the tests, which are recommended in IEC 61400-21 standard. Therefore, in this section, the electrical characteristics to be simulated and validated for wind turbines are studied according to the IEC-61400-21-1 standard (IEC 61400-21-1, 2019).

5.1.1 Power quality aspects

330 The power quality test of WTs consists of measurement of harmonic emissions and flicker tests. Flicker addresses the voltage fluctuations imposed by WTs under continuous and switching operation conditions. Mainly, the flicker effect is considerable for the first generation of WTs without power converters, which were widely connected to distribution power systems in the previous millennium. The harmonic emission consists of current harmonics, inter-harmonics (non-integer multiples of the fundamental frequency), and higher frequency components during continuous operation.

335 The power quality of the emulated AC grid can be arranged based on the emulation type, including HVDC or AC connection, as well. Accordingly, the power quality aspects can be emulated for DUT. The flicker can be generated by adding a low-frequency component to the fundamental frequency of reference signals for AC grid emulator converters in accordance with standards. Also, to study the harmonic interactions of WTs in a WPP, the harmonic injection tests are done in some test sites (Gevorgian et al. (2016); PROMOTiON D16.5 (2019)). Depending on the converter switching frequency of the AC grid
 340 emulator, output filter, and transformers bandwidth, some of low order harmonics can be injected to the terminal of DUT. To date, there is no dedicated standard or regulation for harmonic interaction studies.



5.1.2 Steady-state operation test

The steady-state operation test evaluates the active power (P) production against wind speed, maximum power, and reactive power (Q) capability of DUT. These characteristics aim to validate the power-speed and P-Q curves. The test procedure and
345 necessary data measurements are provided in IEC 61400-21-1 (2019).

5.1.3 Control performance test

Active and reactive power related controls by wind power can be divided into two major categories: WT level controls and WPP level controls. Control performance testing of each of these categories requires special technique. The methods discussed in this paper are related to the WT level controls. In this way, control performance refers to the ability of a WT in terms of
350 active and reactive power control and grid frequency support. The assessment of power control performance is verified by set-point tracking speed and steady-state error of the control system. Also, the grid frequency support includes the active power reduction as a function of the grid over-frequency conditions. Providing additional active power during under frequency events is another grid frequency supporting feature, which should be evaluated through the relevant tests.

5.1.4 Transient performance test

The transient performance or fault-ride through (FRT) capability consists of low voltage ride-through (LVRT) and high voltage ride-through (HVRT) capabilities. Within the last decade, several serious WT tripping incidents have been reported in different countries such as Germany, China, and the UK due to voltage dips (under-voltage) and swells (over-voltage). Voltage transients finally have led to cascaded system trips, over-voltage excursion in transmission systems, and serious frequency deviations in power grids (Langstadtler et al. (2015);Wiser et al. (2018);Zhang et al. (2016)). Also, the measurements on real WPPs have
360 shown that during HVDC converter blocking, the voltage at the WT terminals may increase by 30%, and even it can spike up to 2.0 per-unit (pu) by other transient processes (Erlich, 2016). These incidents indicated the necessity of HVRT and LVRT capabilities for WTs. Consequently, by facing similar problems, some countries, such as Germany, Denmark, Spain, the USA, Italy, and Australia, have adapted the national network codes for both HVRT and LVRT capabilities. Accordingly, the FRT capability demands the WTs to tolerate a specified range of high- or low-voltage events for certain periods.

365 The compliance tests can be implemented by giving the voltage reference values for the AC grid emulator as a voltage-time profile according to the network codes. In the case of the LVRT capability test, the DC grid emulator would decrease the DC-link voltage to achieve an efficient modulation index and less voltage stress on switches and filters of the AC grid emulator. However, this is not possible in cases that wind torque emulator is connected directly to the DC grid emulator.

So far, the solutions for the HVRT capability test using full-converters have been either utilization of step-up tap transformers
370 or over-designing of the converters to be able to generate the required over-voltage range. In the case of converters over-design, the DC Grid Emulator should increase the DC-link voltage to make the over-voltage emulation possible for the AC grid emulator. However, using a step-up tap transformer, the nominal output voltage of the converters would be set as such to generate the maximum over-voltage at the output terminal of the transformer, which is connected to DUT.



375 One of the critical specifications of a test setup for FRT tests is the rate of change of voltage (RoCoV) during the emulation
of voltage dynamics for DUT. The AC side converter should be able to simulate over-voltage or under-voltage events very fast.
This is one of the main advantages of converter-based CGIs that can emulate 100% voltage changes within less than 1 cycle of
the fundamental frequency of the grid. The fastness of a converter depends on ESCR, DC-link capacitors, short circuit current
capability of test side converter, control system, and overall system delays.

380 Furthermore, one of the recent studies in dynamic performance is the response of WTs against unbalanced faults. The
unbalanced voltage deviations can be performed by setting positive and negative sequences in the voltage references and
control loops for the AC grid emulator. The emulation of faults with zero-sequence voltage by CGI is challenging. However,
this type of fault emulation is not necessary because of the transformers and three-wire structure of WTs. In such structures,
the zero-sequence does not propagate to the WTs. However, the objective of tests with zero-sequence voltage would be the
assessment of a four-wire sub-system with grounded wire.

385 **5.1.5 Grid disconnection test**

Disconnection from the grid refers to the disconnection and re-connection functions of a grid-connected WT following its
different protection schemes. Protection schemes for disconnection from the grid operate during extreme amplitude changes
or the rate of changes in voltage and frequency of the grid. The relevant test procedure to the protection schemes evaluation is
provided in IEC 61400-21-1 (2019).

390 **5.2 Additional Test Proposals**

In this section, the additional tests to the IEC 61400-21-1 standard tests are proposed, as it is shown in Figure 4. The test
mode selection unit can choose the test options for the test bench. Grid topology and grid characteristics are considered in the
proposed test options to emulate a more realistic grid connection for DUT.

5.2.1 Detailed power system emulation

395 The IEC 61400-21-1 standard considers the tests for a single WT, or it's sub-systems, which can be performed by CGI con-
verters. However, these tests do not address the electrical power network interconnection issues, such as converter interactions
in the WPP level, grid characteristics influences, renewable power generation integration, and power system stability issues.
Detailed power system emulation can be performed through a power-hardware-in-the-loop (PHIL) interface. In this way, the
voltage, current, and frequency references for the CGI converters can be extracted from the overall system model, including
400 WPP, transmission system, and power system models. The CGI would emulate the characteristics of the AC grid for DUT in its
connection point to the simulation model. The detailed power system emulation using the PHIL interface would be an effective
option to perform several tests on the WPP level and analyze the behavior of DUT in extensive system conditions.



5.2.2 Grid-following capability test

The electrical characteristics, which are considered in the IEC 61400-21-1 standard, only concern the performance of DUT in
405 grid-following mode. In this way, the WT_s are considered as current sources that follow the frequency and voltage references
from the connected grid. Therefore, the grid-following capability of DUT addresses the control performance test, which is
done for the nacelle of WT_s in industrial test benches. However, this test can be performed in WT and WPP levels using the
PHIL interface, as well.

5.2.3 Grid-forming capability test

410 Recently, disconnection from the grid has been extended to a new capability for WT_s, called "grid-forming capability." WT_s
with grid-forming capability can perform as a voltage source to form a local AC network during disconnection from the main
power grid and feed local loads. Some manufacturers have designed a new generation of WT_s with more flexible features such
as the grid-forming capability to enhance the stability and reliability of converter-based power generation. According to the
network codes, WT_s are allowed to disconnect from the AC grid during very severe voltage or frequency deviations out of
415 their tolerable ranges. However, grid-forming WT_s can support local loads and increase the reliability of WPPs (PROMOTioN
D1.5, 2017).

Test bench converters can simulate fault situations for DUT to evaluate the grid-forming capability of such WT_s. During the
grid-forming operation of DUT, the CGI should perform as a current source converter and active load for the DUT. This study
case would be more challenging when the WT_s are meant to be used in an HVDC-connected offshore WPP in which there is
420 no considerable local load for the offshore WPP. In all cases, the grid-forming capability is a temporary operation mode, which
would be followed by reconnection to the grid and resuming to the normal operation.

5.2.4 System restoration and black start capability test

Reconnection to the grid or system restoration is the capability of reconnection of WT_s to the grid after an incidental dis-
connection caused by a network disturbance. According to European network codes (Commission Regulation 631, 2016), the
425 system restoration requirements consist of black start, island operation, and quick re-synchronization capabilities. State-of-
the-art WT_s can be equipped with functions such that they can start and run without the need for external auxiliary power
supplies (PROMOTioN D1.5, 2017). Black start capability is one of the impressive new features of WT_s, which helps fast and
environmentally friendly power system restoration.

The black start would be essential for the start-up of a power generation unit or restart after shutting down due to faults. In
430 a WPP, after the system shuts down, some WT_s with black start capability should be energized by an internal storage system.
Then, the energized WT_s should be able to energize the rest of WT_s by producing wind power over time (PROMOTioN D1.5,
2017). A similar process has been described for the black start of converters of an HVDC station (Commission Regulation
631, 2016). The performance of DUT during system restoration conditions can be studied using advanced converter-based test
benches.



435 5.2.5 SCR and inertia emulation test

SCR of the interconnected AC grid has an essential impact on the behavior of WTs. Emulation of a variable SCR and X/R ratio allows studying the control system and stability of WTs. The hardware options regarding variable SCR emulation are a modular selection of parallel converters of the AC side converter unit and DC-link capacitors. The number of converter modules and DC-link capacitors modifies the rating power and ESCR of the AC grid emulator.

440 Besides, the software options for variable ESCR are considering a virtual impedance and current and power limits in the control loops of converters. In Wang (2015), the virtual impedance control method for a converter is studied in detail. Accordingly, the virtual impedance controller behaves as a series-connected impedance at the output of a voltage source converter, which can be implemented using the RTDS system. However, it can make the control system more complicated.

The magnitude of feasible inertial response by wind turbine generator and related stability implications would be highly
445 dependent on the location of the WPP in the power grid and SCR of PCC. The grid emulator would allow exploring these limits using the RTDS system and relevant control schemes for the CGI converters. Therefore, it is possible to emulate all inertia range from the conventional generation ($H_{dc}=14s$) down to HVDC-connected offshore grids ($H_{dc}=0s$) in a test environment to assess the performance of WTs. In Zhu (2013), the inertia emulation control method using converters of an HVDC system is proposed. It is shown that the inertia of a voltage source converter depends on the number of capacitors, DC-link voltage, and
450 output frequency. So, these options can be used for inertia emulation by CGI for DUT.

5.2.6 Different grid connection test

As it was described in section 4, AC and HVDC transmission systems impose different electrical characteristics and control rules on WPPs. The converter-based CGIs allow emulating these differences in a test environment for the DUT. The control and operation system of an HVDC system depends on the structure of the HVDC converters as well. As it is illustrated in Figure 4,
455 there are three general topologies for HVDC converters: line commutated converters (LCC-HVDC), voltage source converters (VSC-HVDC), and diode rectifier units (DRU-HVDC). The CGI converters have IGBT or IGCT switches in reversed-parallel connection with diodes. The converter switching method can be adjusted to perform switching based on the type of emulated HVDC topology.

The DRU-HVDC system is a cost-effective option to be used in offshore wind power transmission. It is possible to reflect a
460 DRU system by the AC side converter without any additional hardware. Therefore, in this mode, all of the test-side converter switches should be turned off, and the remaining diodes can operate as a DRU converter. On the other side, the DC grid emulator should perform DC voltage regulation. The control methods for an HVDC connection of an offshore WPP using the DRU concept have been studied in PROMOTiON D3.2 (2017) and Saborío-Romano (2019).



6 Conclusions

465 In this paper, the generic topology of industrial test benches and IEC 61400-21-1 recommended tests for network code compliance examinations are investigated. According to the structure of available industrial test benches, there is a strong potential for general harmonized topology and methods for test and assessment of WTs. Primarily, the focus of tests had been on power quality and fault ride-through capability. However, the new features of modern WTs, such as Grid-forming, system restoration, black start, and frequency support capabilities, have been new topics in wind turbine technology. Besides, increasing
470 challenges in WPPs, such as converters interactions, harmonic resonances, and weak grids, have concerned the industry. Test and assessment of wind turbines and sub-systems in a test site allow studying and analyzing the performance and reliability of converter-based power generation. Accordingly, the additional test options regarding new features of WTs, such as Grid-forming, system restoration, black start, and frequency support capabilities, as well as grid characteristics emulation, such as detailed power system, inertia, SCR, and different grid connection emulation tests for DUT, were proposed in this paper. By
475 real-time simulation of a detailed power system, several tests such as WTs interactions and stability issues can be emulated for DUT in WT and WPP levels.

Most of the available advanced test sites are developed based on full-converters consisting of GCI or grid emulator, and wind torque emulator. Therefore, the characteristics of a real power system, that device under test is exposed to at its PCC, can be emulated by a CGI coupled with RTDS systems through a high-bandwidth power-hardware-in-the-loop interface. This
480 way, the AC grid emulator can replicate all characteristics of PCC in terms of AC or HVDC connection types, grid impedance, ESCR, and X/R ratios, the frequency response of the whole power system, and control interactions between DUT and other components of the grid.

The future works would involve in the implementation of the proposed additional test options and measurement data analysis. The authors aim to propose and evaluate new test methods using available advanced test benches to increase their beneficial
485 applications in the assessment of wind energy and reduce the necessity of field tests, which are difficult and costly.

Author contributions. BN developed the new ideas of the paper with intense supervision of PES. BN and PES contributed to writing the original draft. VG and OG did a helpful review and editing of the paper. BN, PS, and VG developed the general test bench structure. All co-authors contributed to the control methodology and plotting of figures. BN prepared the manuscript with contributions and revisions from all co-authors.

490 *Competing interests.* No competing interests are present.

Acknowledgements. This project has received funding from the European Union's Horizon 2020 research and innovation program under grant agreement No. 691714.



References

- Global statistics of global wind energy council (GWEC), 2018. Available online at <http://gwec.net/global-figures/graphs/>.
- 495 Wind Europe, Wind energy in Europe: Outlook to 2022, September 2018.
- IRENA, Nurturing offshore wind markets: Good practices for international standardisation, Inter. Ren. Energy Agency, Abu Dhabi, 2018.
- PROMOTioN, "Deliverable 11.1: Harmonization catalogue," 2019.
- NERC, Integration of Variable Generation Task Force: Summary and Recommendations of 12 Tasks, 2015.
- Commission Regulation (EU) 2016/ 631 - of 14 April 2016 - establishing a network code on requirements for grid connection of generators.
- 500 Commission Regulation (EU) 2016/ 1447 - of 26 August 2016 - establishing a network code on requirements for grid connection of high voltage direct current systems and direct current-connected power park modules.
- Ausin, J. C., Gevers, D. N., and Andresen, B.: Fault ride-through capability test unit for wind turbines, *Wind Energy*, 11, 3–12, <https://doi.org/10.1002/we.255>, 2008.
- IEC 61400-21-1:2019 – Wind energy generation systems - Part 21-1: Measurement and assessment of electrical characteristics - WTs.
- 505 Langstadtler J., Brelie B. S. D., et al. "Relevance of high voltage ride-through capabilities and testing," CIREN, 23rd Intern. Conf. on Electricity Distribution, 2015.
- Mohamed Asmine, Charles-Éric Langlois "Wind power plants grid code compliance tests – Hydro-Québec TransÉnergie experience" *IET Renew. Power Gener.*, vol. 11 Iss. 3, pp. 202-209, 2017.
- V. Gevorgian, P. Koralewicz, "Controllable Grid Interface for Testing Ancillary Service Controls and Fault Performance of Utility-Scale Wind Power Generation," 15th Inter. Workshop on Large-Scale Integ. of Wind Power into Pow. Sys. for Offshore WPPs, Austria, 2016.
- 510 Lorenzo Zeni, Vahan Gevorgian, Robb Wallen, et al. "Utilisation of real-scale renewable energy test facility for validation of generic wind turbine and wind power plant controller models," *IET Renew. Power Gener.*, 10, (8), pp. 1123 – 1131, 2016.
- D. V. Hertem ; O. Gomis-Bellmunt; J. Liang "HVDC GRIDS: For Offshore and Supergrid of the Future," Wiley-IEEE Press, ISBN:9781118859155, 2016.
- 515 Cutululis, N. A. (Ed.) (2018). MEDOW - Multi-terminal DC Grid for Offshore Wind, Final report. DTU Wind Energy. (DTU Wind Energy E; No. 317221).
- Das, K., and Antonios Cutululis, N. (2017). Offshore Wind Power Plant Technology Catalogue: Components of wind power plants, AC collection systems and HVDC systems.
- Erika Pierria, Ole Bindera and et al. "Challenges and opportunities for a European HVDC grid" *journal of renewable and sustainable energy reviews*, vol. 70, pp 427-456, 2017.
- 520 Ryan Wisser, Mark Bolinger and et al. "Wind Technologies market Report", 2018.
- B. Nouri, A. Arasteh and et al. "Comparison of European Network Codes for AC and HVDC-connected Renewable Energy Sources," 18th Wind Integration Workshop on Large-Scale Integration of Wind Power, Dublin, 2019.
- B. Andresen, F. Martin and et al. "IEC TC 88 Wind Power Generation Standards in Relation to Grid Connection Requirements," 18th Wind Integration Workshop on Large-Scale Integration of Wind Power, Dublin, 2019.
- 525 IEC TR 61400-21-3:2019 - Wind energy generation systems - Part 21-3: Measurement and assessment of electrical characteristics - Wind turbine harmonic model and its application
- Poul Sorensen, "IEC 61400-27 Series – Electrical Simulation Models of Wind Generation Systems," 18th Wind Integration Workshop on Large-Scale Integration of Wind Power, Dublin, 2019.



- 530 Espinoza, N. and Carlson, O.: Field-test of wind turbine by voltage source converter, *Wind Energ. Sci.*, 4, 465–477, <https://doi.org/10.5194/wes-4-465-2019>, 2019.
- N. Espinoza, M. Bongiorno, and O. Carlson, "Novel LVRT testing method for wind turbines using flexible VSC technology," *IEEE Trans. Sustain. Energy*, vol. 6, no. 3, pp. 1140–1149, Jul. 2015.
- Y. Yang, F. Blaabjerg et al., "Benchmarking of voltage sag generators," in *Proc. Annu. Conf. IEEE Ind. Electron. Soc.*, 2012, pp. 943–948.
- 535 MEGAVIND, 2016, "Test and Demonstration Facilities for Wind Energy Needed to promote a Competitive Wind Industry in Denmark," Available online at <https://megavind.winddenmark.dk/test-and-demonstration-facilities>
- N. R. Averous, and et al. "Development of a 4 MW Full-Size Wind-Turbine Test Bench," *IEEE JOURNAL OF EMERGING AND SELECTED TOPICS IN POWER ELECTRONICS*, VOL. 5, NO. 2, 2017.
- Vahan Gevorgian, NREL, "NREL Controllable Grid Interface (CGI): Overview of Progress and Projects," 5th Annual Int. Workshop on Grid Simulator Testing of Energy Systems and WT Powertrains, Tallahassee FL, 2018.
- 540 Torben Jersch, IWES, "Wind Assuring Confidence Through Competence," 5th Annual International Workshop on Grid Simulator Testing of Energy Systems and WT Powertrains, Tallahassee FL, 2018.
- Lars S. Rasmussen, LORC, "LORC Nacelle Testing," 3th Annual Int. Workshop on Grid Simulator Testing of Energy Systems and WT Powertrains, Tallahassee FL, 2015.
- 545 ABB, 2018, Medium voltage AC drive, https://library.e.abb.com/public/d30de1862c34d04dc1257b0c00551f88/ACS_6000_EN_RevD-3.pdf
- GE, 2018, "GE's Power Conversion," Available online at <https://www.gepowerconversion.com>
- Kai Pietilainen, ABB, "Grid Simulator Trends," 5th Annual International Workshop on Grid Simulator Testing of Energy Systems and WT Powertrains, Tallahassee FL, 2018.
- Christoph Buchhagen, Christian Rauscher, et al. "BorWin1 – First Experiences with harmonic interactions in converter dominated grids," Intern. ETG Congress, (VDE VERLAG gmbh, Berlin), 2015.
- 550 Ł. H. Kocewiak, S. Chaudhary, B. Hesselbæk, "Harmonic Mitigation Methods in Large OWPPs," in *Proc. 12th Inter. Workshop on Large-Scale Integr. of Wind for O. W. Farms*, Energynautics GmbH, Germany, 2013.
- I. Sowa, J. L. Domínguez-García, O. Gomis-Bellmunt, "Impedance-based analysis of harmonic resonances in HVDC connected offshore wind power plants," *Electric Power Systems Research* 166 (2019) 61–72.
- 555 IEEE Guide for Planning DC Links Terminating at AC Locations Having Low Short-Circuit Capacities, IEEE Standard 1204-1997, 1997.
- Lingling Fan and Zhixin Miao, "An Explanation of Oscillations Due to Wind Power Plants Weak Grid Interconnection," *IEEE TRANSACTIONS ON SUSTAINABLE ENERGY*, VOL. 9, NO. 1, 2018.
- A. Yogarathinam, J. Kaur and N. R. Chaudhuri, "Impact of Inertia and Effective Short Circuit Ratio on Control of Frequency in Weak Grids Interfacing LCC-HVDC and DFIG-Based Wind Farms," *IEEE TRANSACTIONS ON POWER DELIVERY*, VOL. 32, NO. 4, 2017.
- 560 J. Z. Zhou, Hui Ding and et al. "Impact of Short-Circuit Ratio and Phase-Locked-Loop Parameters on the Small-Signal Behavior of a VSC-HVDC Converter," *IEEE TRANSACTIONS ON POWER DELIVERY*, VOL. 29, NO. 5, 2014.
- Poul Sørensen, Nicolaos A. Cutululis, et al. "Power Quality Issues on Wind Power Installations in Denmark" IEEE conf. paper, 2007.
- D.M. Joseph, P. Haigh and J. McCullagh, "ENSURING GRID CODE HARMONIC COMPLIANCE OF WIND FARMS" 11th Wind Integration Workshop, 2012.
- 565 Ł. H. Kocewiak, B. Gustavsen, and A. Hołdyk, "Wind Power Plant Transmission System Modelling for Harmonic Propagation and Small-signal Stability Analysis," in *Proc. The 16th Wind Inter. Workshop*, Energynautics GmbH, Germany, 2017.
- M. Bradt, B. Badrzadeh and et al. "Harmonics and Resonance Issues in WPPs," in *Proc. IEEE Power Energy Soc. General Meeting*, 2011.



- V. Preciado and M. Madrigal, et al. "Harmonics in a Wind Power Plant," IEEE Power and Energy Society General Meeting, 2015.
- Jian Sun, "Impedance-Based Stability Criterion for Grid-Connected Inverters," IEEE TRAN. ON POWER ELEC., vol. 26, no.11, 2011.
- 570 PROMOTioN, "Deliverable 16.5. Implementation of an Analytical Method for Analysis of Harmonic Resonance Phenomena," 2019.
- M. Durrant, H. Werner, and K. Abbott, "Model of a VSC HVDC terminal attached to a weak sys.," IEEE Conf. Cont. Appl., Turkey, 2003.
- Lidong Zhang, Lennart Harnefors, and Hans-Peter Nee, "Interconnection of Two Very Weak AC Systems by VSC-HVDC Links Using Power-Synchronization Control," IEEE TRANSACTIONS ON POWER SYSTEMS, VOL. 26, NO. 1, FEBRUARY 2011.
- P. Koralewicz, V. Gevorgian, and R. Wallen, " Multi-Megawatt-Scale PowerHardware-in-the-Loop Interface for Testing Ancillary Grid Ser-
- 575 vices by Converter-Coupled Generation" Power Oscillation Damping from Offshore Wind 18th IEEE Workshop on Control and Modeling for Power Electronics (COMPEL), 2017.
- Yuning Zhang, Ningning Tang, et al. "Wind energy rejection in China: Current status, reasons and perspectives," jour.of Ren. and Sus. Energy, vol. 66, pp. 322–344, 2016.
- I. Erlich, B. Paz, "Overvoltage Phenomena in O. W. Farms Following Blocking of the HVDC Conv.," IEEE Po. and En. Society Gen.
- 580 Meet.(PESGM), 2016.
- PROMOTioN, "Deliverable 1.5: Quantification of requirements," 2017.
- Xiongfei Wang, YunWei Li, and et al. "Virtual-Impedance-Based Control for Voltage-Source and Current-Source Converters" IEEE TRANSACTIONS ON POWER ELECTRONICS, VOL. 30, NO. 12, DECEMBER 2015.
- J. Zhu, C. D. Booth, "Inertia Emulation Control Strategy for VSC-HVDC Trans. Sys.," IEEE TRAN. ON POWER SYS., VOL.28, NO.2,2013.
- 585 PROMOTioN, "Deliverable 3.2: Specifications of the control strategies and the simulation test cases," 2017.
- Saborío-Romano, O., Bidadfar, A., Göksu, Ö., Zeni, L., and Cutululis, N. A. (2019). Power Oscillation Damping from Offshore Wind Farms Connected to HVdc via Diode Rectifiers. Energies, 12(17). <https://doi.org/10.3390/en12173387>